

Installation guide Sight glass

Type SGP X, SGP I, SGP N, SGP RX, SGP RI, SGP RN, SGR, SGI, SGRI, SGN, SGRN



014R9572

014R9572

Refrigerants: SGP: HCFC, HFC, HC and R744 (CO ₂) SG: HCFC / Non- flammable HFC	Media temperature: T _{min} : -50 °C / -58 °F T _{max} : 80 °C / 175 °F	Max. working Pressure: SGP: PS/MWP = 52 bar / 754 psig SG: PS/MWP = 35 bar / 508 psig
--	---	---

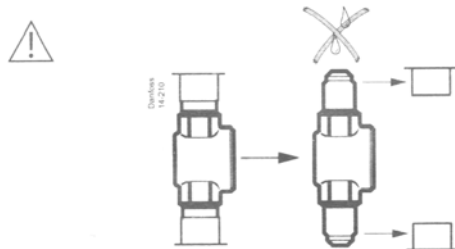
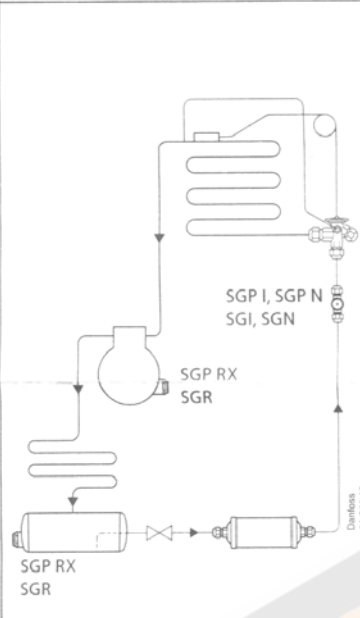

SGP I/SGP N, SGP RI/SGP RN, SGI/SGN, SGRI/SGRN

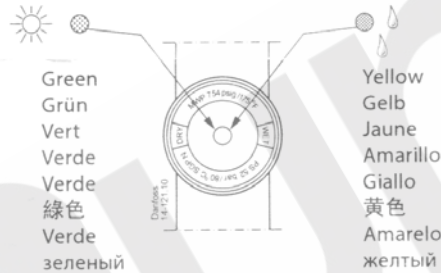

SGP/SG solder
d > 22 mm - 7/8 in.

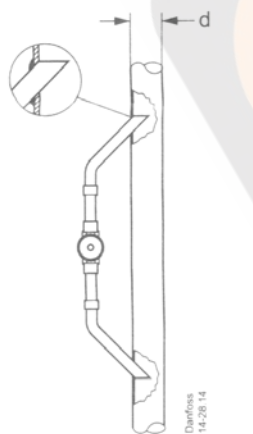

SGP/SG solder

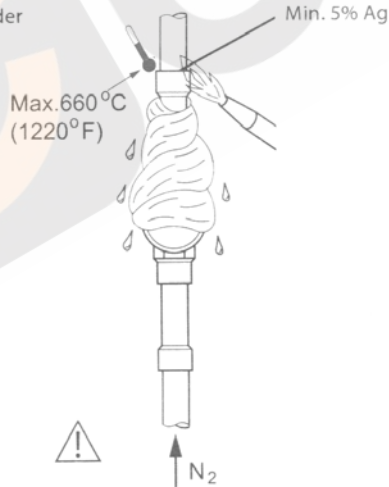

SGP/SG flare

Type	W		W	
	mm	in.	mm	in.
SGP/SG flare 6	14	9/16	16	5/8
SGP/SG flare 10	19	3/4	22	7/8
SGP/SG flare 12	22	7/8	24	15/16
SGP/SG flare 16	27	1 1/16	27	1 1/16
SGP/SG flare 19	32	1 1/4	32	1 1/4

SGP/SG flare

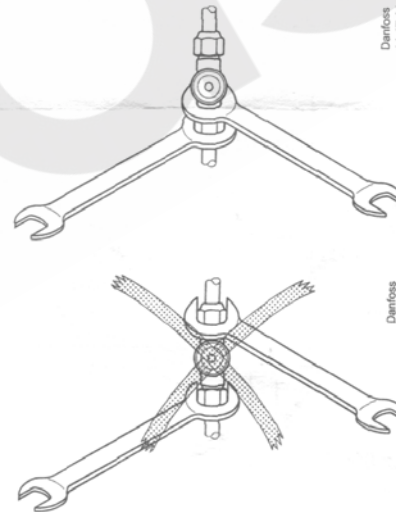

SGP/SG socket

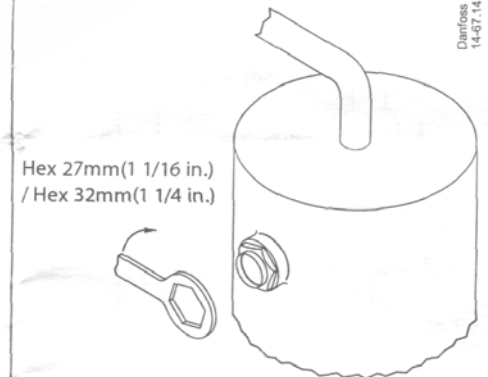

SGP/SG socket max. torque 100 Nm (74 ft-lbs).

Max. torque		
Size	Nm	ft-lbs
1/4 in. / 6 mm	20	15
3/8 in. / 10 mm	30	22
1/2 in. / 12 mm	60	44
5/8 in. / 16 mm	100	74
3/4 in. / 19 mm	200	148

With O-ring max. torque 50 Nm (37 ft-lbs).